

# CARRL

CLEAN AIR RAPID REGIONAL LINK

Presented By: Team Maximum Capacitance

Addison Hern  
 Michael Hodgson  
 Parker Vascik  
 David Diaz  
 Benjamin Bitoun  
 Jeffery Brenna  
 Michael Steinfeld  
 Robert Barrett  
 Stephen Fialko

TEAM  
 123

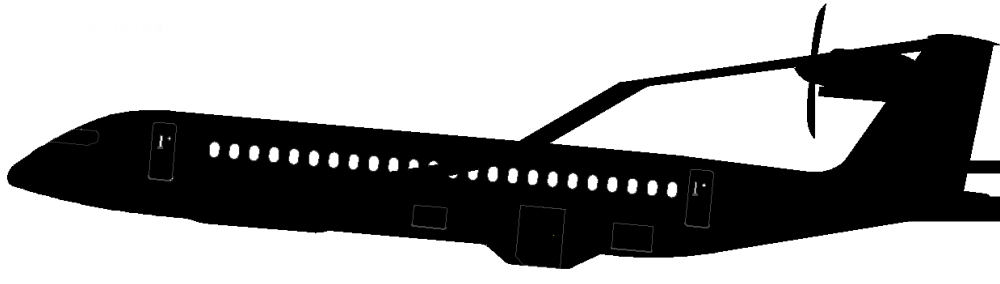

## CARRL Subsystem Spotlight



### Ground Service

A full analysis of both in route and terminal service was conducted for CARRL. This was used to size and locate service bays for optimal turnaround time.

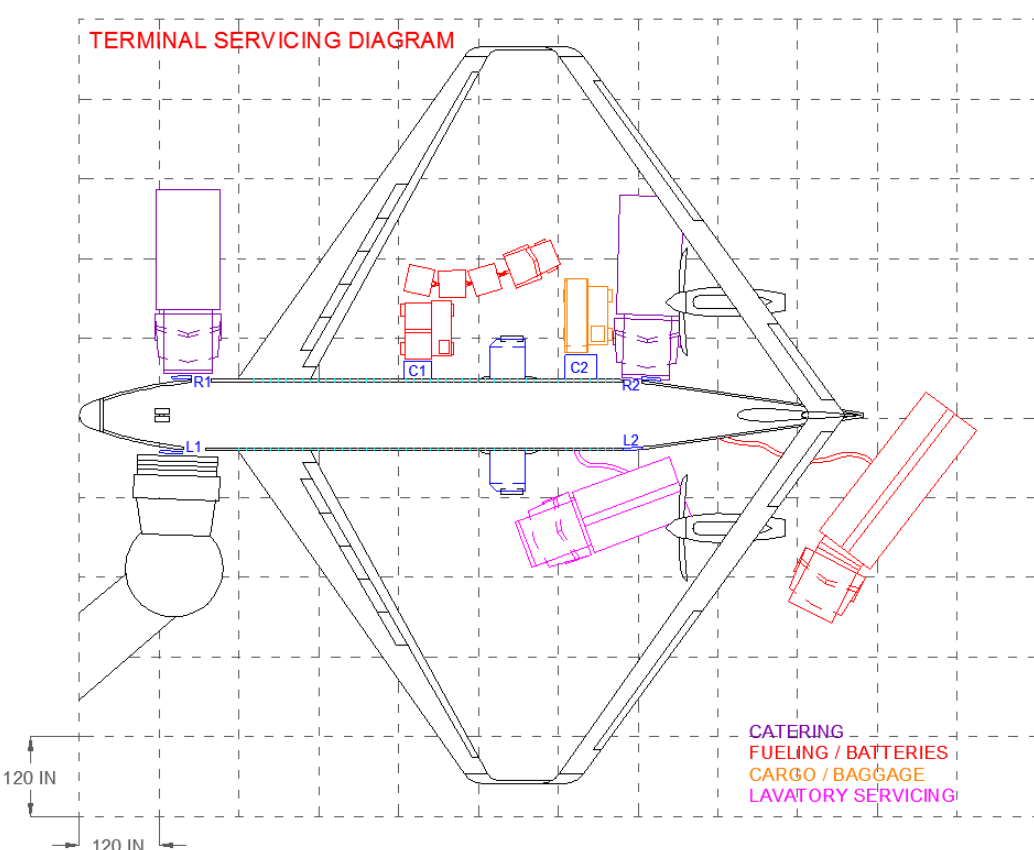

CARRL's Battery Loader takes the needs of all stakeholders into account and reduces turnaround time. It is designed with ground service personnel in mind to function similarly to existing cargo container loading systems using trolleys, an elevator, and a conveyor system to facilitate loading through a small service bay.

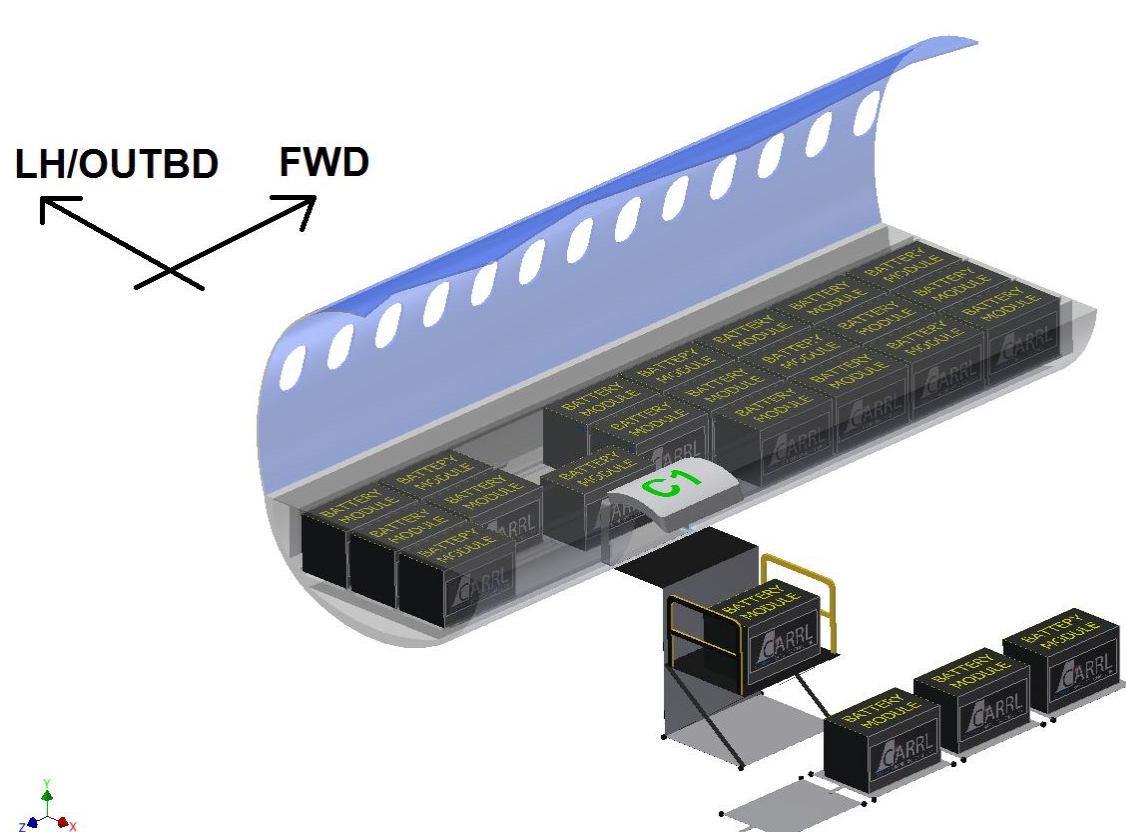

### Passenger Comfort



CARRL features large windows, while maintaining strength by using a composite fuselage tube. This, coupled with small wing chords due to a box wing design, leaves an unobstructed view of the sky to nearly every passenger.



BL 3520 Image Courtesy of Recaro

Even CARRL's seats leverage cutting edge design to increase passenger comfort (More Legroom - 11.4" on CARRL vs. 10" on SkyWest CRJ-700) and decrease weight. (40% Lighter than Current Models)

### Boxwing Design

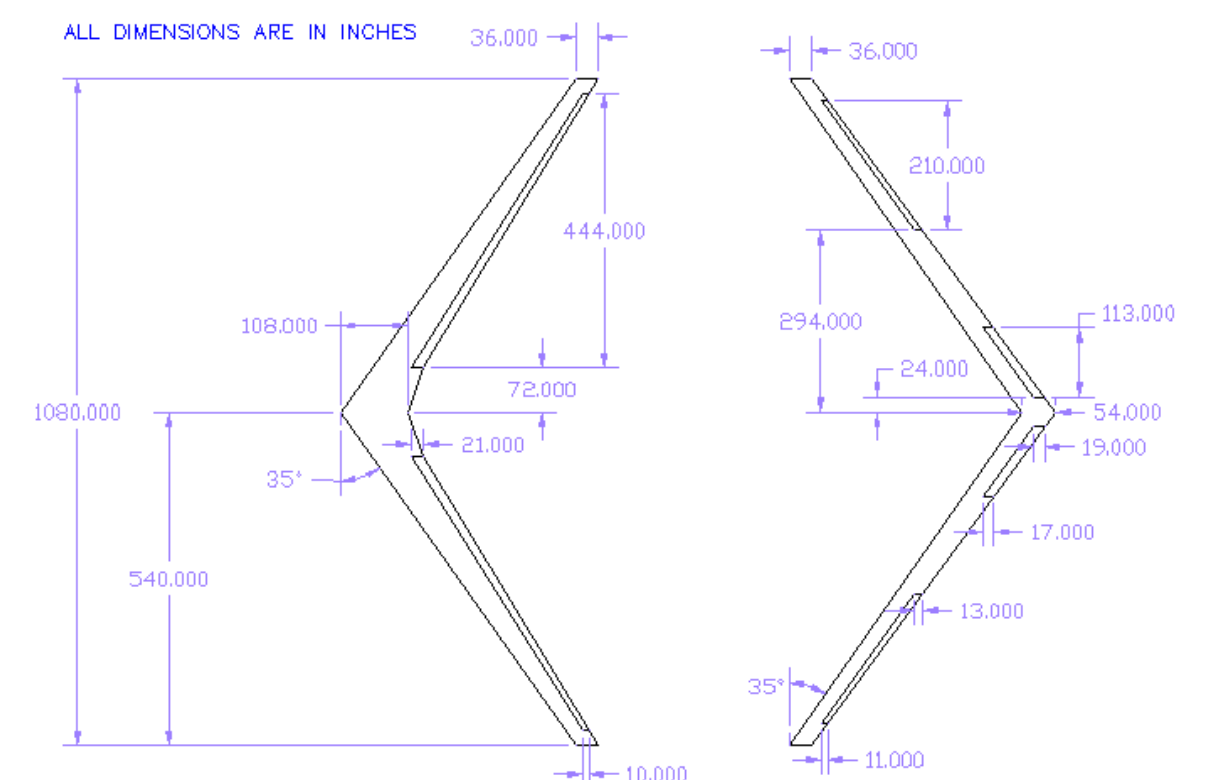

CARRL's box wing offers up significant structural advantages as well as a comparably high AR for its ground footprint. However, it was worried customers might be put off by any unfamiliar aircraft configuration. Thus, a market research survey was conducted with help from the College of Business.

"It's just cool! I love the design and I know that it's innovative and safe or it couldn't be in the air. I'd love to fly in that!!"

Would you be willing to fly in an aircraft with a "Box Wing" configuration?

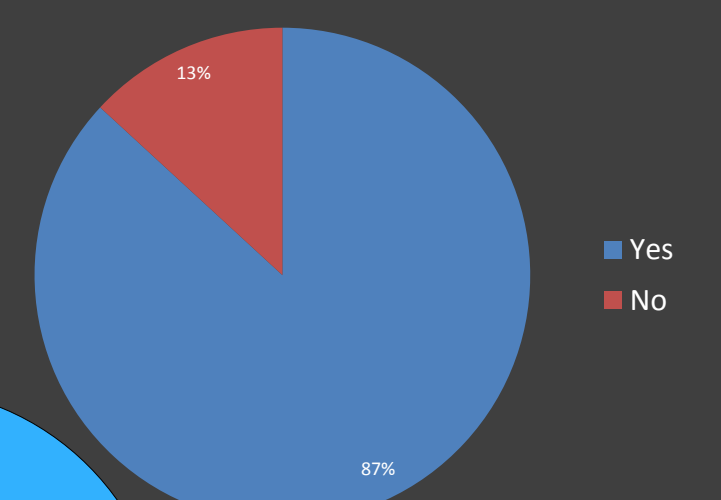

"The joined wing looks [stronger] and thus seems safer."